

Hackman News

February 2011



HACKMAN

Green Light for Spring Business with Hackman!

After a short recession time in the global economy seems to be recovering - at least when looking at the accelerated business activities of Hackman partners in different markets. Kitchen operators have courage to invest, especially when it comes to cost saving cooking systems and modern, temperature-controlled serving lines, which Hackman is pleased to offer.

Our R&D Teams will bring many advanced product features to the market this year. Our factories continue to investment into production technology in order to reduce costs and to improve quality. Further we will improve our customer service with two new people, who will concentrate on serving our international partners in the areas of stainless steel fabrication and Nordien System & food distribution products.

Our products will be exhibited during the year in many international trading shows over three continents and, of course, HOST in Milan in October will be welcoming all of your teams to Hackman Stand.

We wish to our partners very active, warm and sunny business during this spring & summer!

Pekka Mönkkönen
Director of Business Unit
HACKMAN

HACKMAN



HACKMAN SORSAKOSKI FACTORY – The Specialist for S/S Work Stations

The Hackman Sorsakoski Factory markets, designs and manufactures Taylor-Made stainless steel furniture for very wide range of customers.

The end users of our products are from professional kitchens in the public sector, restaurants, retail chains. Carpentry Industry, Wholesale companies and Cleanroom suppliers. We also cater to private customers.

The Main market area is the Nordic Countries, where Hackman are one of the leading manufacturers in the s/s work stations sector.

In S/S Work Stations, Hackman has three different product families resulting a very diverse range.

PROFF-LINE



HACKMAN



CLASSIC-LINE



- Traditional solutions for professional kitchens
- Suitable for all kinds of productive kitchens
- Ergonomic workstations with high hygiene standards
- Strong constructions
- Taylor-made solutions
- **Also flat-pack tables available**
- Suitable also for other Customer segments, e.g. dairy industry and hospitals (rinsing rooms)

BASIC-LINE



Flat-pack tables:

Small package size saves transportation space

- **Saving in logistic costs!**

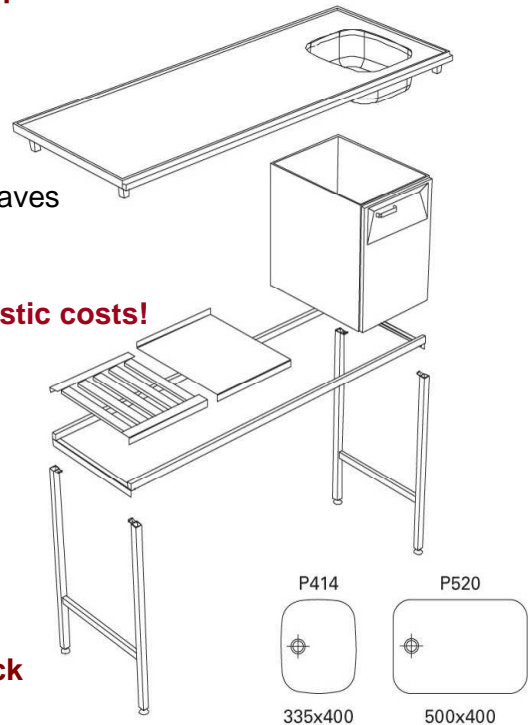

Easy and quick to assemble!

- Limited assortment of standard tables and accessories
- **Tables available also as a flat-pack version**
- For Customers, who appreciate very advantageous price

HACKMAN



HEIGHT ADJUSTABLE TABLES – High Ergonomics



type ATE
- only with electric lift



A table with hydraulic lift
- type ATHM with manual lift
- type ATHE with electric lift

Wide range of tables
and accessories

- **Hydraulic tables by manual or electric lift**
- For Customers, who appreciate high level of ergonomics
- **Made in Finland**

Contact persons at Hackman Sorsakoski factory:

TOMMI KÄRKKÄINEN

Sales Manager for Nordic Countries



email: tommi.karkkainen@hackman.com

tel. + 358 204 39 4913

fax + 358 204 39 4915

ILPO PIIRONEN

Plant Manager



email: ilpo.piironen@hackman.com

tel. + 358 204 39 4901

fax + 358 204 39 4915

HACKMAN





DISTRIBUTION NEWS

A new invention in Nova distribution units structure has been made. This updated structure will be presented in the upcoming Hackman News issue as well as the schedule for the launch.

A new handy glass stand has been added to our assortment. The new stand is called GSS and can be ordered with the code 4321234. The price is the same as for the previous round version with code 2025319.

Organization changes

Antti Myllys is moving to another position within the Metos group, and the position of distribution sales will be filled by **Marika Löfman**. Marika has worked within the group for 10 years and is already familiar with most of the products. Marika will be in contact with the customer once she has taken her position. This is effective starting 1.3.2011.

